

EE 230
Experiment 10
ECG Measurements
Spring 2010

Note: If for any reason the students are uncomfortable with doing this experiment, please talk to the instructor for the course and an alternative experiment will be assigned. Although we believe this experiment to be safe, electrodes will be placed on the body to take measurements and if large electrical signals are injected into these electrodes, the subject could be seriously injured or killed. We will exercise a reasonable level of precaution in this experiment but can not guarantee that the experiment is completely safe.

CAUTION: MUST READ the FOLLOWING TWO PARAGRAPHS BEFORE PROCEEDING

When conducting this experiment, the following procedures **MUST** be followed. First, the only piece of electrical equipment that should be attached to the circuit board when electrodes are attached to the body is the oscilloscope. Make sure that the ground terminal of the oscilloscope is connected to the ground in the circuit. Second, when the electrodes are attached to the body, the biasing of all circuitry should be with two 9V dc batteries. Third, students should only connect electrodes to a student when another individual is present and a TA or the course instructor is in the room. Finally, if for any reason any electrical shocks are experienced, immediately remove the electrodes from the subject.

In preparation of the circuits, a “Body Emulator” will be built. The body emulator is a simple circuit that will provide signals of about the same amplitude as the ECG signals. The “Body Emulator” will be used during the development stages of this experiment. In this experiment, only two dc power supplies should be used, one should be set at +9V and the other at -9V. When working with the Body Emulator, normal laboratory procedures should be followed. Before the “Body Emulator” is replaced with the actual electrodes attached to the subject, disconnect the +9V and -9V dc power supplies and disconnect all test equipment except for the oscilloscope. Replace the +9V and -9V dc power supplies with 9V batteries. Verify that the circuit is still working using only the oscilloscope to make measurements with the 9V batteries. After the circuit performance is verified with the “Body Emulator” and the two 9V batteries, connect the electrodes on the subject in place of the two voltages on the “Body Emulator”. Any trouble shooting that is undertaken when the electrodes are placed on the subject should use only the oscilloscope for measurements. An optical isolator is often used when making measurements on the body and provides additional isolation between the test subject and the external instrumentation. To keep the scope of this measurement at a reasonable level, an optical isolator will not be used here.

This experiment will focus on measuring electrocardiogram (ECG) signals that are present on the surface of the skin. Some refer to these as ECG signals and others use the term EKG signals to denote the same signals. The ECG signals are generated by the heart and are used by cardiologists and physicians as a part of an evaluation process to determine if the heart is operating properly. ECG signals are also monitored in

pacemakers and defibrillators to assess how the heart is performing. Abnormalities or changes in the ECG trigger action by the pacemaker or defibrillator.

If two electrodes are placed at suitable locations on the surface of the skin, a waveform similar to that shown in Fig. 1 will be obtained.

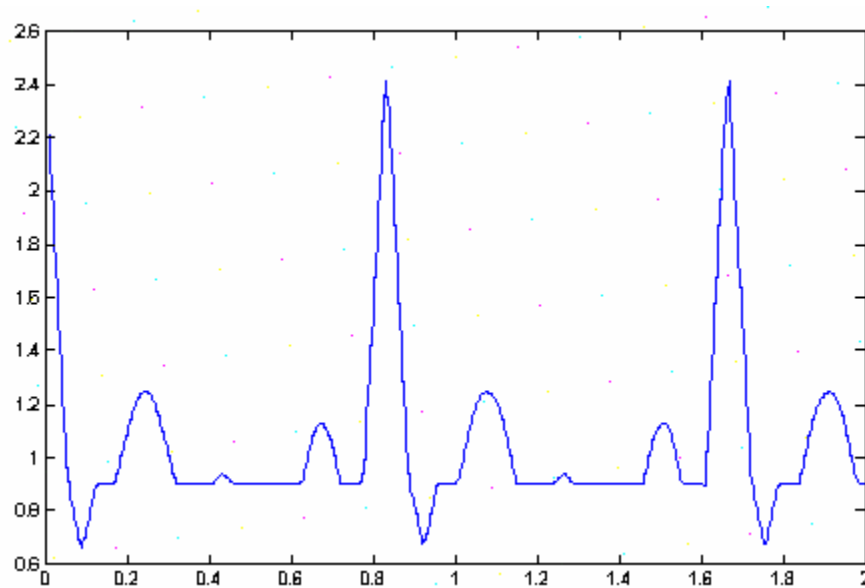

Fig. 1 Artists Depiction of Electrocardiogram (from www.mathworks.com/.../fx_files/10858/1/ecg.jpg)

There will be one major peak every time the heart beats. The magnitude of this peak will depend upon where the electrodes are placed and will vary somewhat from patient to patient. The peak amplitude is in the 1mV range (400uV to 2mV are typical). As the heart muscle contracts, the shape of the ECG signal will change and there is considerable information not only in when the peaks occur and in the shape of the waveform in the vicinity of the peaks but also in the smaller peaks that appear between the major peaks. Unfortunately there is a lot of noise present on the surface of the skin and also in the amplifiers that are used to amplify these small signals so the real signal that will be obtained is not nearly as ideal as that shown in Fig. 1. It will be corrupted by a rather high level of noise that may also be in the mV range or sometimes even larger. Medical equipment that is used to obtain ECG signals includes signal processing algorithms that remove as much of the noise as possible without excessively distorting the signal information that is present in the ECG signals.

In this experiment, emphasis will be placed on obtaining the ECG signal and on removing enough of the noise to make the major peaks separate themselves from the noise that occurs between. Most of the signal information in the ECG signal is at low frequencies, likely between 0.5Hz and 50Hz. Consequently a highpass filter is often used to reject dc components that may be present in either the incoming signals or in the amplifiers themselves. Likewise a lowpass filter is often used to reject higher frequency components. Finally, large 60Hz signals are often present. If the lowpass filter has steep

band edge somewhere between the signal band and 60 Hz, the 60Hz interfering signal can be reduced. Sometimes a narrow-band notch filter is also included to specifically reject the 60Hz signal. Since the pole frequencies of these filters is quite low, the required capacitor values tend to get rather large making the use of one or more electrolytic capacitors is particularly attractive for building these filters. Electrolytic capacitors can be used but the normal operation of the circuit must not attempt to reverse bias the electrolytic capacitors. This issue will be discussed later in this experiment.

Body Emulator

This circuit will be used to generate signals that are comparable in amplitude to the ECG signals that will be obtained at the surface of the skin. An electrical model of the signals that will be picked up at the surface of the skin is shown in Fig. 2. The

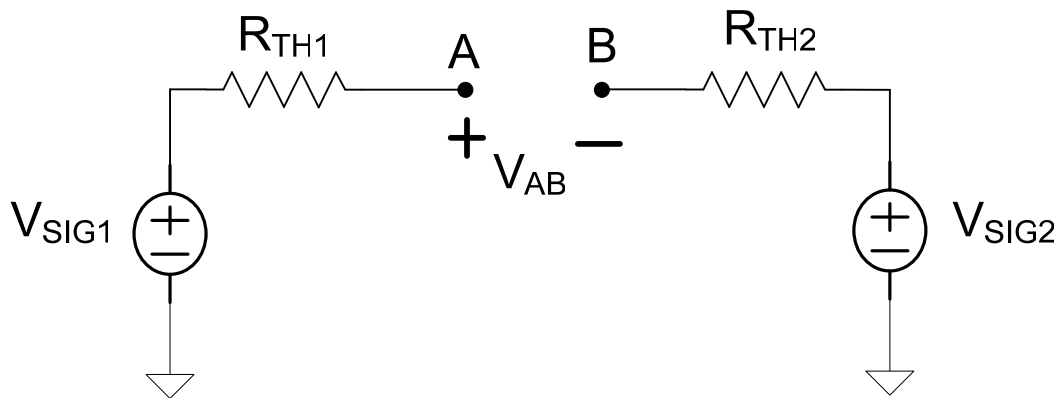

Fig. 2 ECG Signals on the skin surface

ECG signal of interest is $V_{ECG} = V_{SIG1} - V_{SIG2}$. Note that the desired signal is the difference of two single-ended signals. Thus, three electrodes will ultimately be required. The placement of these electrodes on the body will be discussed later. There is a thevenin equivalent impedance in series with the two signals so the signals that will actually appear at the input to an amplifier are the signals on nodes A and B. The actual voltage that will be measured is the difference voltage V_{AB} . Of course, the instrumentation should have a high input impedance so that there is little voltage drop across R_{TH1} and R_{TH2} .

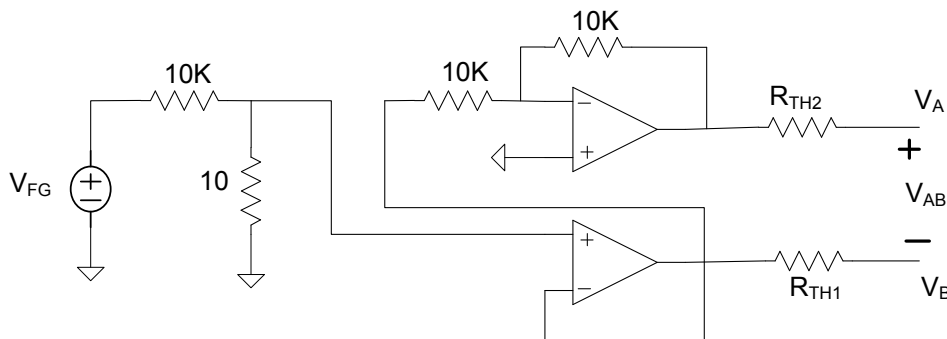

Fig. 3 ECG Body Emulator

An ECG Body Emulator is shown in Fig. 3. V_{FG} represents the output of the function generator. If the Function Generator is programmed to output a 500uV pulse of duration 10mS once every second, this will be a crude approximation of the ECG signal. The 10K to 10 Ω attenuator will reduce the amplitude of this pulse to about 500uV. The output signals from the two operational amplifiers should be complimentary 500uV pulses. The resistors R_{TH1} and R_{TH2} represent the thevenin impedances of Fig. 2.

Thevenin Impedances

The thevenin impedance is difficult to obtain since it is comprised of the impedance of the skin contact in series with the internal impedance to the source of the voltage. Although there is not a point voltage source internal to the body, the model of Fig. 2 should suffice for this experiment. If we assume that the internal impedance is small compared to the skin contact impedance, this impedance can be rather easily measured. You might first want to measure the impedance between two points on the body by placing two test leads on the skin and then measuring the impedance with the multimeter. Then, place two electrodes with conductive grease provided by the TA on the surface of the skin and repeat the measurement with the multimeter. MAKE sure you are measuring the resistance with the multimeter. The two electrodes can be placed on ONE arm in the vicinity of the wrist about 4 inches apart. Assuming the two impedances are about the same, the thevenin impedances, R_{TH1} and R_{TH2} should be about half of the measured impedance. How much difference do you see in the impedance by placing two test leads on the skin and by placing two electrodes on the skin with conducting grease?

ECG Amplifier and Filters

Many different circuits can be used to build the difference amplifier and the filters. Fig. 4 shows a basic instrumentation amplifier that is widely used for measuring ECG signals. Note the input impedance is ideally infinite for both inputs. The output of this amplifier is single-ended making it possible to follow this with single-ended filters.

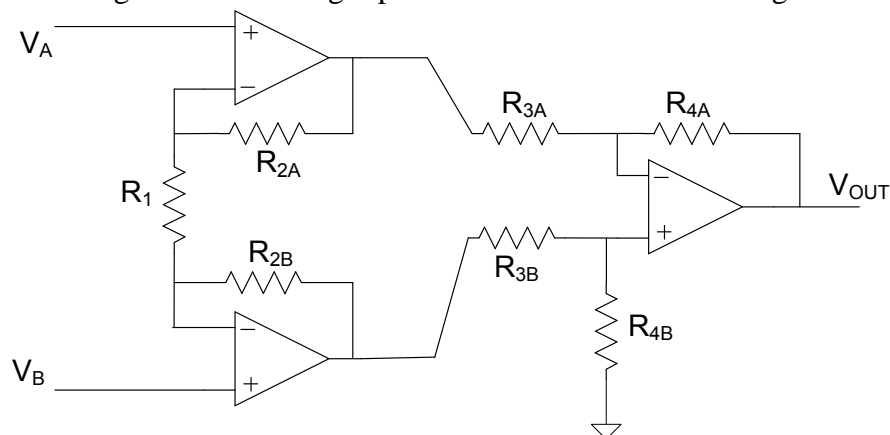

Fig. 4 Basic Instrumentation Amplifier

Ideally the “A” and “B” values of the corresponding resistors are identical. This shows everything being direct coupled and is adversely affected by offset voltages of the amplifiers if the gains of the amplifiers are large. Methods for reducing the effects of

offset voltage were discussed earlier in the course. Remember when designing the differential amplifier and any filters to use +/- 9V power supplies.

Using Electrolytic Capacitors to Build Filters

When it is necessary to have filters with low frequency poles, the size of the required capacitors often becomes quite large making it particularly attractive to use electrolytic capacitors. But, if the first-order lowpass filter shown in Fig. 5a were used with an electrolytic capacitor, the capacitor would become reverse biased when the output voltage goes negative for an extended time and this would be unacceptable.

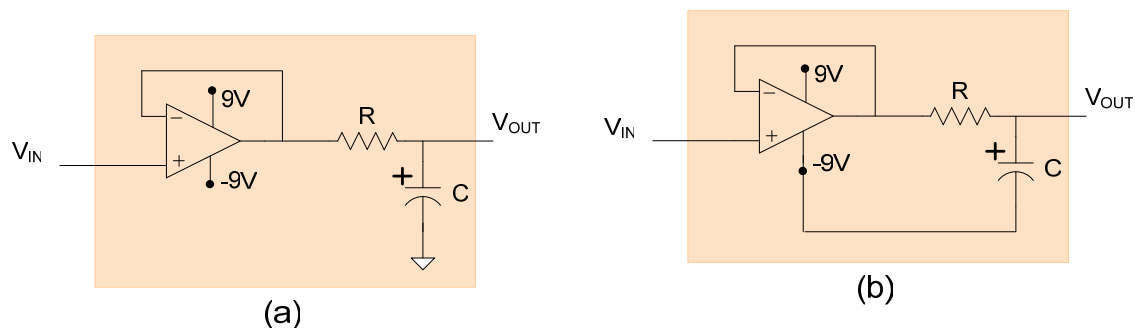

Fig. 5 Using electrolytic capacitors in filter circuits

By simply connecting the “-“ terminal to the most negative supply voltage in the circuit, this capacitor will never become reverse biased. It can be shown that the circuit of Fig. 5b has the same transfer function as that of Fig. 5a but in the latter case the electrolytic capacitor can be used since it never becomes reverse biased. Although this example focused on the lowpass filter, similar methods can be used when it is desired to utilize electrolytic capacitors in other filter circuits.

Driving LEDs on Pulse Edges

Circuits that provide a short-duration pulse on a rising or falling edge of a signal are termed monostable multivibrators. The operation of monostable multivibrators is similar to that of the triangle and square wave generators that were discussed in class. Monostable multivibrators are discussed in the text for this course.

Laboratory Procedure

Part 1. Design and test a “Body Emulator” that can be used for helping in the design of the ECG amplifier

Part 2. Design and test an amplifier circuit that will amplify the ECG signals so that the peak amplitude of the ECG signal is between 5V and 8V. Your laboratory report should include several periods of the ECG signal you obtained. Be sure that you also include an analysis of any amplifier circuits and filter circuits you use along with the measured

performance with the Body Emulator in your report. These circuits should all be tested with the Body Emulator and other appropriate test equipment before the test electrodes are attached to the body.

(When attaching the electrodes, attach the ground electrode to the right leg near the ankle. Attach the two signal electrodes to the left and right wrists. Use alcohol and a cotton ball to remove any surface oils prior to attaching the electrodes). Be sure to have your TA check the circuit prior to attaching the electrodes. Remember that the circuit should be powered by 9V batteries any time the electrodes are attached to the patient.

Part 3. Add a circuit to the amplifier that will turn on a RED LED for 0.1sec every time the heart beats.

Parts 1, 2, and 3 must be completed. As discussed above, differing levels of filtering will affect the quality of the ECG signal. The grading of this experiment will depend, in part, on how clean of a signal is obtained in Part 2.